

Slicer TS500

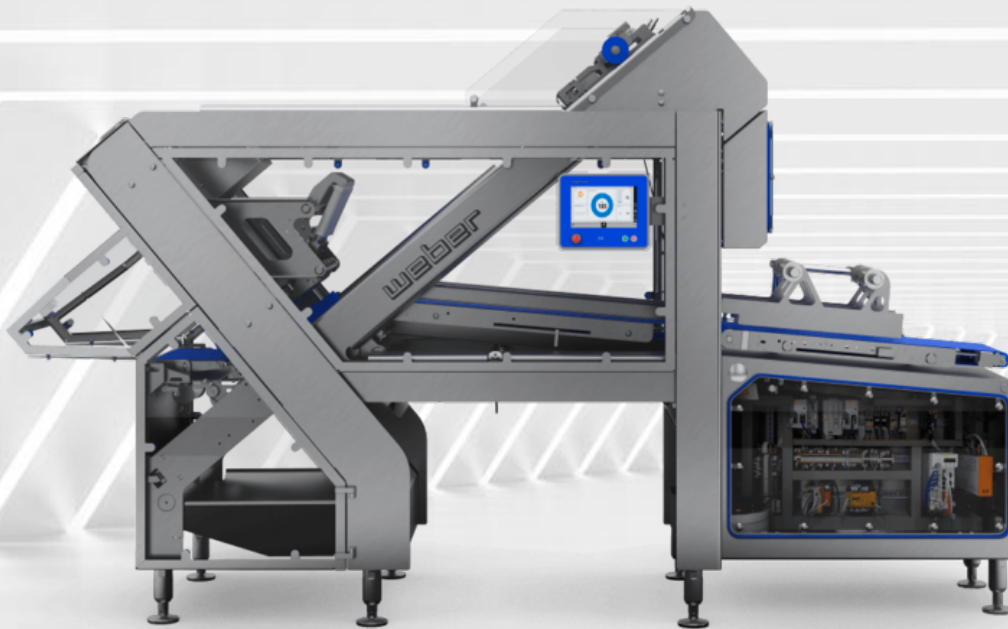

Product details

- Slicer with circular blade technology
- Large product passage
- High ease of maintenance

View online



Advantages

 Circular blade

 Weber Hygiene Design

 Variogripper

 Quick set-up time

 SprayTech

 Interleaver

 Automatic loading













Slicer TS500

Good output when slicing the product gently at the same time - a task that the Weber Slicer TS500 easily masters with its combination of circular blade technology, large product passage and very short reloading time. The powerful TS500 convinces with a new, open design and innovative slicer functions.

- GripnGo reloading function
- VarioFeed Product Feeder
- ContiFlow - Slicing without reloading gaps

Optionally, the slicer is also available with an idle cut function.

Presentation

- | | | | |
|--|--|---|---|
|  Stacked |  Staggered Stack |  stacked-with-interleave |  Shingled-stack |
|  Shingled |  Shingled-with-interleave |  Endless-shingled |  Pieces |
|  Shaved |  Folded |  Portion-designer |  Overlapped - single/mixed |
|  Multiple-overlaps - single/mixed | | | |

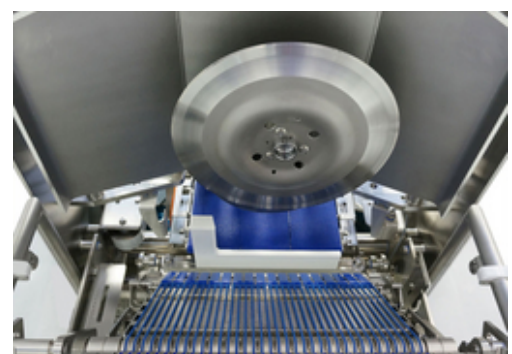

Technical Data Slicer TS500

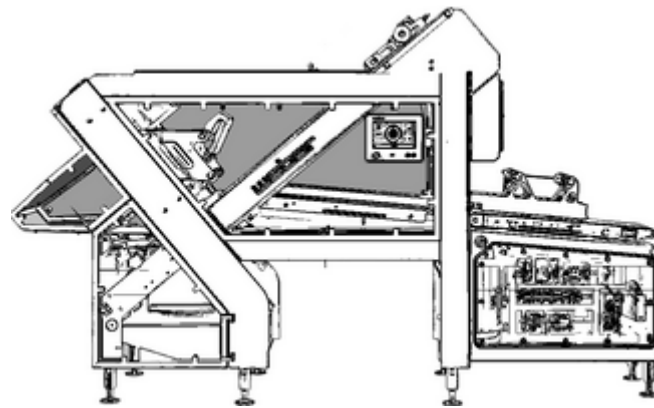

Product throat height (mm)	170
Product throat width (mm)	420
Product length (mm)	1200, 1600, 1850
Slicing system	Circular blade system
Loading (automatic/manual)	automatically
Involute blade cutting speed (rpm)	max. 750

Weber means: service across the board.



Weber Academy.

Maximize line performance through professional training courses.

At the Weber Headquarter in Breidenbach, Germany, we have our own training center, the Weber Academy. Being a provider of complete line solutions, we offer training courses for your Weber Line, tailored precisely to your needs. In doing so, our focus is always on increasing efficiency and optimizing profit in your company.



Weber Guardian.

A safe plan for your production.

Only those who listen can understand. And those who understand can act. With our Weber Guardian program, we harmonize people, machines, and processes to get the most out of production. From preventive maintenance and inspection through targeted personnel development to production support and optimization.



Weber Portal.

Networked thinking, handling together.

You will find everything about your Weber equipment bundled in your personal Weber Portal. Compact, individual and interactive. From your customer profile and that of your machines to e-learning on your setup as well as convenient spare parts ordering and service offers. Are you already registered?

We are looking forward to your message.



Rob Unwin
Operations Director



Andre Clareboets
Joint Head of Sales



Tom Foran
Divisional Manager – Slicing

Legal notice

This document was generated automatically on 09/05/2023. All information is non-binding. We reserve the right to make changes in the interest of technical progress. For the latest information on this product, please visit:

<https://www.weberweb.com/portfolio/slicer/slicer-ts500/>