

THE FIRST OF ITS TYPE

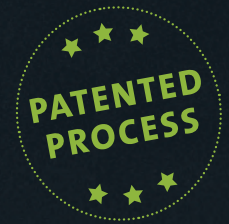

Mixer grinder U 200 mm 1300 L / 1850 L

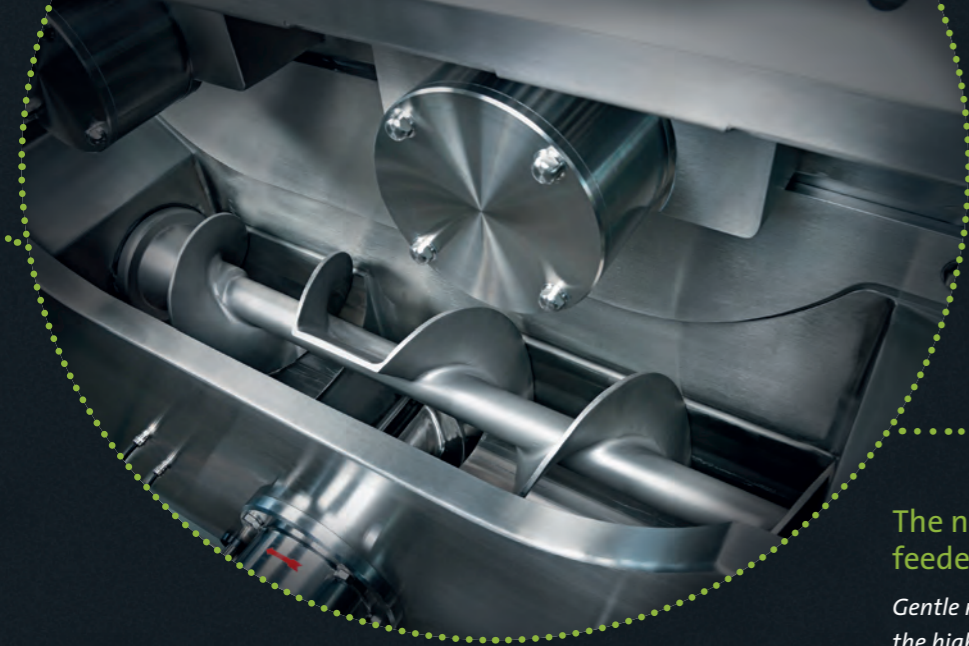



The new feeder worm

Gentle material feed with the highest efficiency.



Perfectly coordinated with each other

Mixing shaft and mixing hopper

Separation

of the product and mixing section from the drive section

Individual control

Via touch panel



NEW STANDARDS IN EVERY RESPECT

GRINDING AND MIXING WITH NO LOSSES

And it really works! The mixer grinder from K+G Wetter makes it possible: dead-space-free mixing. The new generation mixes much more efficiently, even without a worm in the mixer section. With the MW 200, K+G not only offers THE SOLUTION for standardised products such as burgers and raw sausage products, but also for a wide range of convenience products.

- This saves energy, cost and time.
- Innovative technology allows mixing and grinding in a single machine, without the previously associated disadvantages such as material (dead space) and time losses.
- In conventional models the mixing shaft and screw-conveyor are located together, within the feed hopper. The result: “Dead spaces”—areas inside the hopper that the mixing paddle cannot reach—are created during processing.
- The residual material remaining inside the machine (up to 15 kg) has previously had to be added to a subsequent mix or has been ground in an unmixed state.
- Both have negative effects; either through delaying the process or by lowering quality. Both are history with the new mixer grinder from K+G Wetter.

A SMALL STEP FOR K+G WETTER ...

... but a giant leap for the meat processing industry. The K+G Wetter principle has led to a completely novel solution: The mixer section and grinder section are completely separated from one another. The meat worm feeder unit is the underlying innovation behind the new mixer grinder generation from K+G. The absolutely trouble-free mixing process guarantees a new production standard:

- Gentle material feed, minor warming, no smearing.
- The dead space losses have been overcome.
- The result is a high-grade, homogeneous end product.
- By opening the hydraulically-operated discharge gate the hopper is quickly and fully emptied through two discharge ports.
- A state-of-the-art, pivoting touchscreen facilitates flexible operation of the machine – even during cleaning.

Normal mixing principle

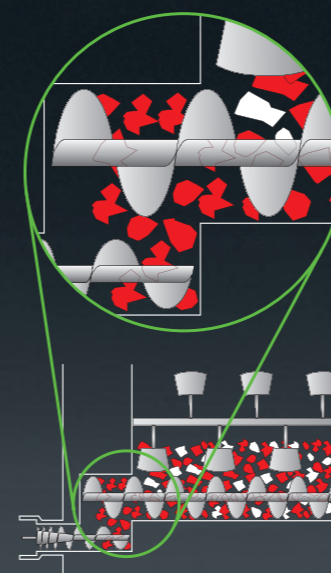

MW 200 mixing principle

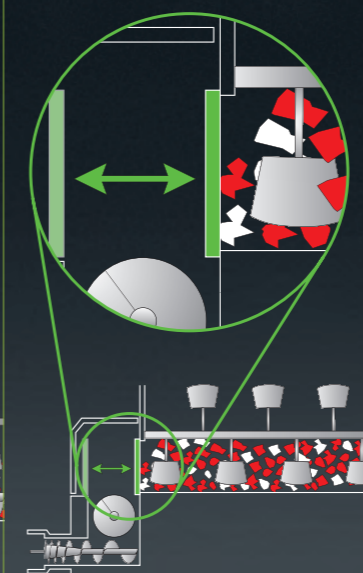

Dead-space-free mixing

Separating the mixing section from the feeder and meat worm guarantees a zero-loss mixing result (top right).

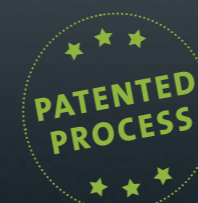

THE SUM OF ITS BENEFITS ...

- ... defines this machine generation.
- Two mixer paddle shafts are each driven by a geared motor.
- Co-rotation and counter-rotation are possible in each direction.
- Rotational speeds can be varied.
- The best possible mixing results are achieved.
- Both the electric controller and the hydraulic unit are integrated into the machine stand.
- The bearing unit and the food area are clearly separated to allow perfect cleaning.
- For cleaning purposes, the feeder worm can be removed without using tools.
- The CutControl recipe management software allows reproducible and consistent mixing and grinding processes, resulting in the very best product quality.
- Using the CutVision quality management software all steps in the production process can be recorded, analysed and saved.

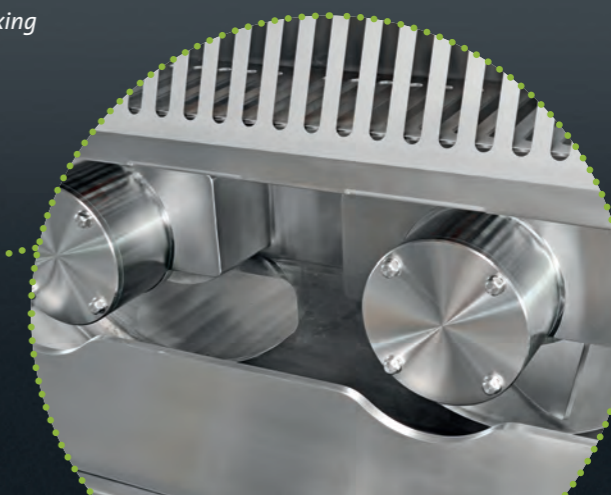

The innovative transfer zone

between the mixing hopper and feeder worm

DATA, TECHNOLOGY AND OPTIONS



Mixer grinder U 200 / 1300 L

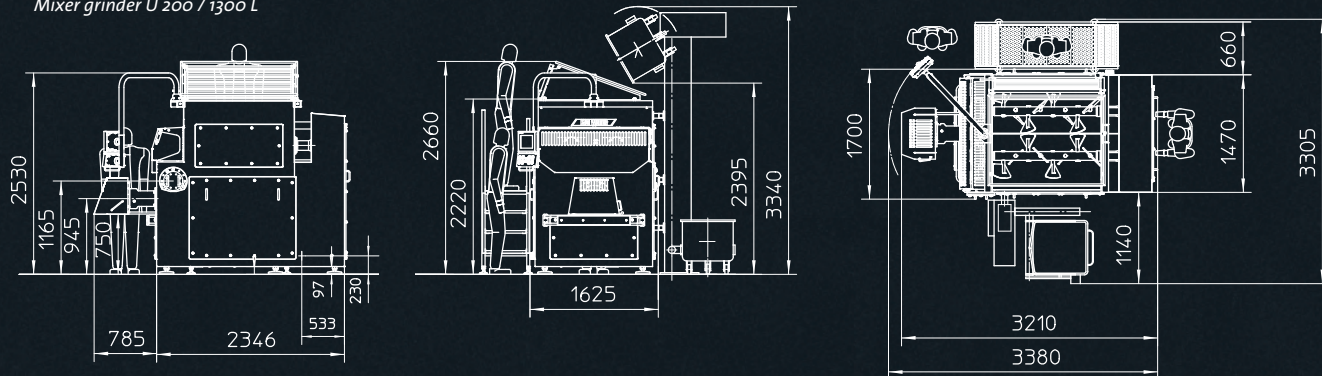

Mixer grinder U 200 / 1850 L

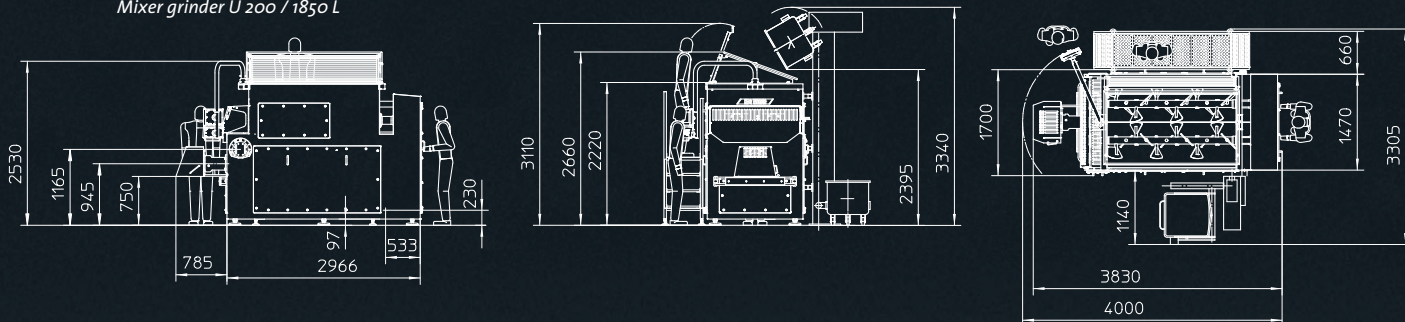

All dimensions in mm

OTHER EQUIPMENT AND FUNCTIONAL OPTIONS

- Water dosing
- CO₂ cooling unit (only for MW U 200 / 1300 L)
- Pneumatic sorting device
- Bayonet lock nut
- Support unit for the pre-cutter
- Reverse operation (brief) of the meat worm
- Loading device
- Central lubrication
- Hydraulic meat worm ejecting device
- Cleaning and transport trolley
- Weighing system

TECHNICAL SPECIFICATIONS

	MW U 200 / 1300 L	MW U 200 / 1850 L
Hopper volume	1,300 litres	1,850 litres
Mixing capacity	700-900 kg	1000-1300 kg
Meat worm drive	30 / 48 kW	
Mixer shaft drive	2 x 13 kW	
Feeder drive	1,5 kW	
Electrical fuse protection	139 Amp	
Sound pressure level (idle speed)	70 dBA	



K+G WETTER GmbH
Goldbergstraße 21
35216 Biedenkopf-Breidenstein

Tel. +49 (0) 64 61 / 98 40 - 0
Fax +49 (0) 64 61 / 98 40 - 25

info@kgwetter.de
www.kgwetter.de