

next step in sawing

CC5-H

CONTINUOUS CUTTING MACHINE

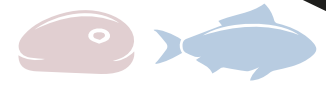

Machine specially designed to apply **four longitudinal cuts (centered or not centered)** into a product. The machine is loaded manually by the operator and the cut is applied by means of four band saw blades in a completely safe way.

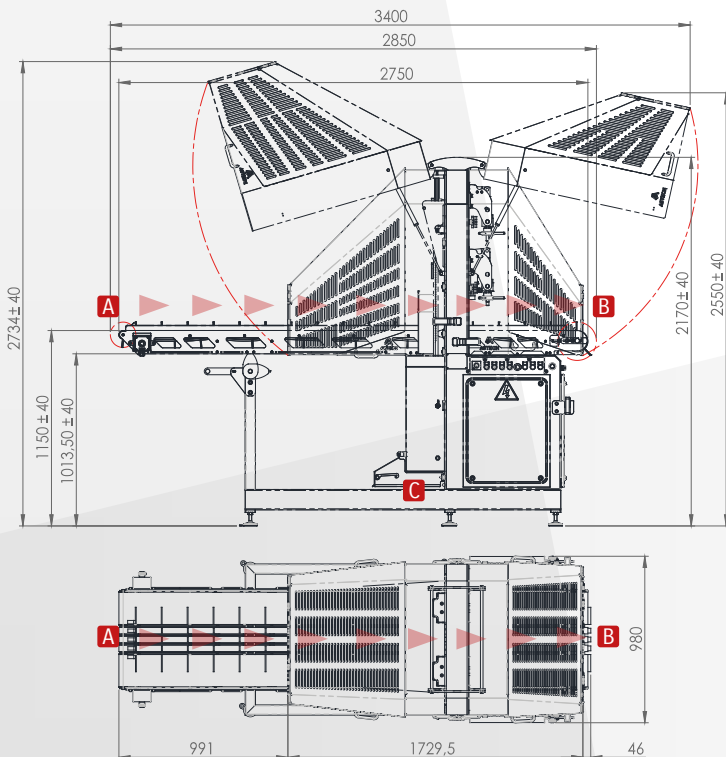
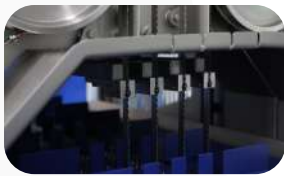

■ TECHNICAL FEATURES

- ▶ Ext. dimensions 2850 x 980 x 2170 ± 40 mm
- ▶ Open cover height 2735 ± 40 mm
- ▶ Outfeed height 1050 ± 40 mm
- ▶ Band saw motor speed --- 1500 rpm

■ CONNECTIONS

Electricity

- ▶ Installed power 12.1 kW
- ▶ Voltage 400V (3~) 50/60 Hz
- ▶ Machine consumption ---- 27 A

Water

- ▶ Consumption..... 60l/h (maximum)

Compressed air

- ▶ Precision 6 bar (4 bar minimum. Less than 4 bar the machine gives an error)
- ▶ Consumption 0,5 l/complete cutting cycle
- ▶ Inlet pipe diameter Ø10 mm

A Product Infeed

B Product Outfeed

C Saw dust discharge in a 600 x 400 x 200mm E-2 crate